

## 20A Range Current Sensor Module ACS712

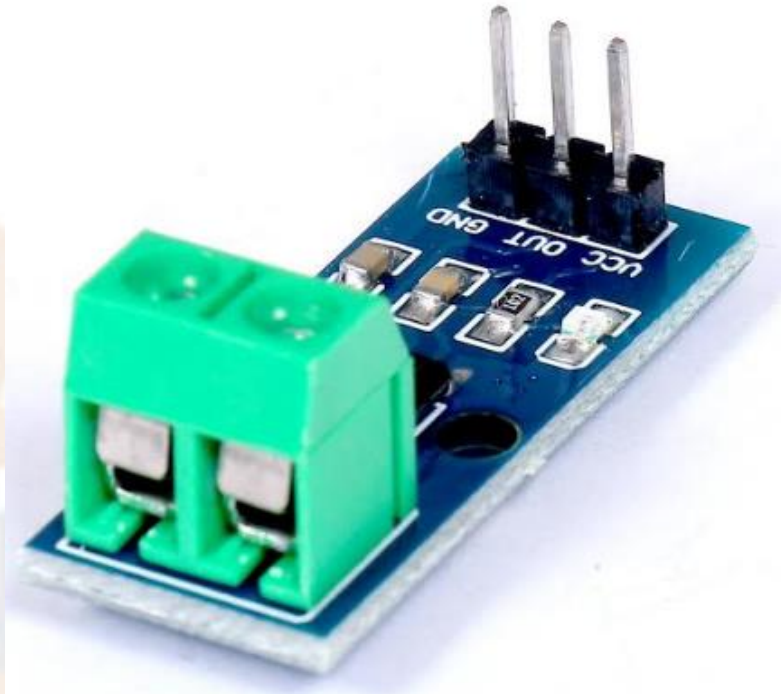

ACS712 Current Sensor Module - 20A can sense upto 20A of current flow. Sensing and controlling the current flow is a fundamental requirement in wide variety of applications, which includes over-current protection circuits, battery chargers, switching mode power supplies, digital watt meters, programmable current sources, etc.

ACS712 Current Sensor Module - 20A is based on ACS712 sensor, which can accurately detect AC or DC current. The maximum AC or DC that can be detected can reach 20A, and the present current signal can be read via analog I / O port of a microcontroller or an Arduino.

### FEATURES:

- The low-noise analog signal path
- Device bandwidth is set via the new FILTER pin
- 5  $\mu$ s output rise time in response to step input current
- Small footprint, low-profile SOIC8 package
- 2.1 kV RMS minimum isolation voltage from pins 1-4 to pins 5-8
- 5.0 V, single-supply operation
- 66 to 185 mV/A output sensitivity
- Output voltage proportional to AC or DC currents

- Factory-trimmed for accuracy
- Extremely stable output offset voltage
- Nearly zero magnetic hysteresis
- The ratiometric output from the supply voltage.

**SPECIFICATIONS:**

- Current sensor chip: ACS712ELC-20A
- Operating Voltage (V): 4.5V ~ 5.5V DC
- Measure Current Range: -20 ~ +20A
- Sensitivity: 100mV/A
- Dimension(LxWxH): 32x13.5x5
- Weight(gm): 5

**FUNCTIONAL DESCRIPTION:**

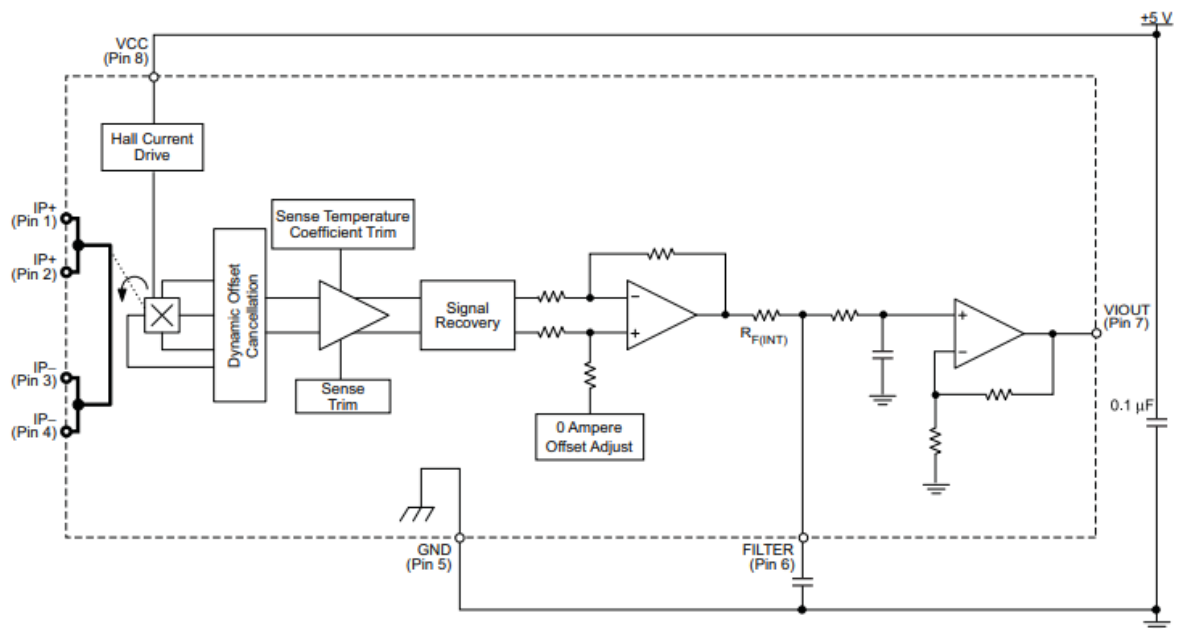

- The ACS712 Module uses the famous ACS712 IC to measure current using the Hall Effect principle. The module gets its name from the IC (ACS712) used in the module, so for your final products use the IC directly instead of the module.
- These ACS712 module can measure current AC or DC current ranging from +5A to -5A, +20A to -20A and +30A to -30A. You have to select the right range for your project since you have to trade off accuracy for higher range modules. This module outputs Analog voltage (0-5V) based on the current flowing through the wire; hence it is very easy to interface this module with any microcontroller.
- The Allegro® ACS712 provides economical and precise solutions for AC or DC current sensing in industrial, commercial, and communications systems. The device package allows for easy implementation by the customer. Typical applications include motor control, load detection and management, switchmode power supplies, and overcurrent fault protection. The device is not intended for automotive applications.
- The device consists of a precise, low-offset, linear Hall circuit with a copper conduction path located near the surface of the die. Applied current flowing through this copper conduction path generates a magnetic field which the Hall IC converts into a proportional voltage.
- Device accuracy is optimized through the close proximity of the magnetic signal to the Hall transducer. A precise, proportional voltage is provided by the low-offset, chopper-stabilized BiCMOS Hall IC, which is programmed for accuracy after packaging.
- The output of the device has a positive slope ( $>V_{IOUT}(Q)$ ) when an increasing current flows through the primary copper conduction path (from pins 1 and 2, to pins 3 and 4), which is the path used for current sampling. The internal resistance of this conductive path is 1.2 m $\Omega$  typical, providing low power loss. The thickness of the copper conductor allows survival of the device at up to 5 $\times$  overcurrent conditions. The terminals of the conductive path are electrically isolated from the signal leads (pins 5 through 8). This allows the ACS712 to be used in applications requiring electrical isolation without the use of opto-isolators or other costly isolation techniques.
- The ACS712 is provided in a small, surface mount SOIC8 package. The leadframe is plated with 100% matte tin, which is compatible with standard lead (Pb) free printed

circuit board assembly processes. Internally, the device is Pb-free, except for flip-chip high-temperature Pb-based solder balls, currently exempt from RoHS.

### WORKING PRINCIPLE:

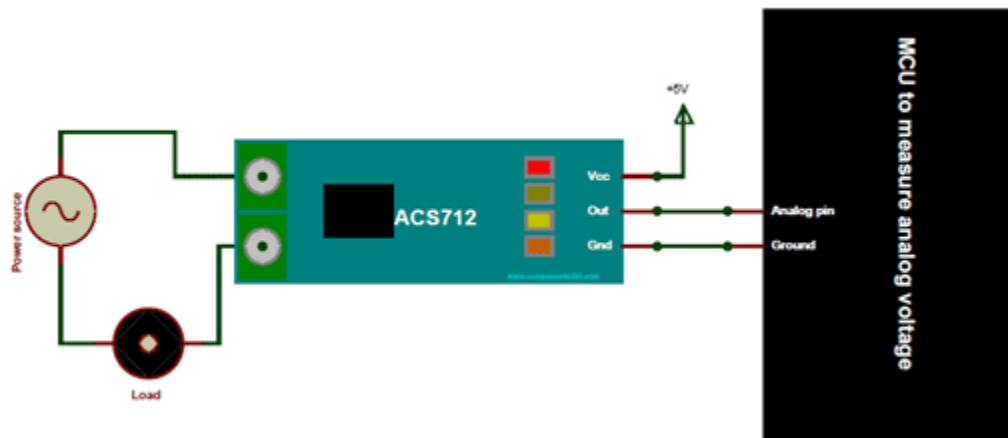

- The ACS712 module has two phoenix terminal connectors (green colour ones) with mounting screws as shown above. These are the terminals through which the wire has to be passed. In our case I am measuring the current drawn by the motor so the wires that is going to the load (motor) is passed through the ACS 712 Module. Make sure the module is connected in series with the load and be extra cautious to avoid shorts. On the other side we have three pins.
- The Vcc is connected to +5V to power the module and the ground is connected to the ground of the MCU (system). Then the analog voltage given out by the ACS712 module is read using any analog pin on the Microcontroller.

### Programming for ACS712 Module

- There are few things to know before we could program our Microcontrollers to read current from ACS712 Module. By default when no current is flowing through the module terminals the output voltage will be +2.5V ( $V_{cc}/2$ ), when the current flows in one direction the value will increase from 2.5V and when it flows in other direction the values will decrease from 2.5V. This way the module enables us to measure both AC current and DC current.
- Let us assume that the microcontroller you are using has a 10-bit ADC and operates at 5V with a reference voltage of 5V for ADC conversion in that case the microcontroller will read the values of ADC from 0 to 1024. Then you can use the formulae below to calculate the Output Voltage from ADC values.

$$\mathbf{V_{out} (mV) = (ADC\ Value / 1023) * 5000}$$

After calculating the output voltage we can, calculate the value of current from the voltage using the below formulae

$$\mathbf{Current\ Through\ the\ Wire\ (A) = (V_{out}(mv) - 2500) / Scale\ factor}$$

Note that the value of scale factor changes for every module based on its range.

### PIN FUNCTION:

#### For IC ACS712:

| Pin No  | Pin Name | Description   |
|---------|----------|---|
| 1 and 2 | IP+      | Terminals for current being sampled; fused internally |
| 3 and 4 | IP-      | Terminals for current being sampled; fused internally |
| 5       | GND      | Signal ground terminal                                |
| 6       | FILTER   | Terminal for external capacitor that sets bandwidth   |
| 7       | VIOUT    | Analog output signal                                  |
| 8       | VCC      | Device power supply terminal                          |

**ACS712 Current Sensor Pinout:**

| Pin No | Pin Name | Description   |
|--------|----------|---|
| 1      | Vcc      | Input voltage is +5V for typical applications                 |
| 2      | Output   | Outputs Analog voltage proportional to current                |
| 3      | Ground   | Connected to ground of circuit                                |
| T1     | Wire In  | The wire through current has to be measured is connected here |
| T2     | Wire Out |   |

**PACKAGE INCLUDES:**

1x 20A Range Current Sensor Module ACS712.